

GE Mining
Industrea

BULLETIN 30071

MINECRUISER BULLETIN



Date: 20/12/2013

Prepared for: Industry

Prepared by:

Ross Stutchbury
 **GE Mining
Industrea**
Ross Stutchbury
Product Line Manager
CPEng 327097 RP 1063



BULLETIN MineCruiser

GE Industrea advises the following information relating to the MineCruiser product.



Communication: Product Improvement Drive shaft hoop

A MineCruiser has become unstable as a result of the rear drive shaft falling to the ground while the machine was in transit. A drive shaft hoop (7-045339-700) to retain a failed drive shaft is now available to suit Mk7 MineCruisers. This simple device will contain the rotational energy in the drive shaft and prevent a failed shaft contacting the ground where the failure occurs on a dynamic vehicle.

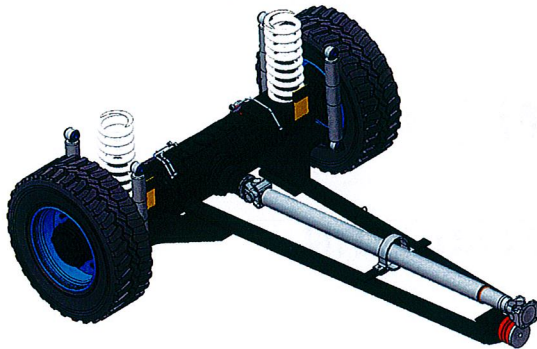

Drive Shaft hoop



Individual Recall: Mk7 MineCruiser Aeon Spring position

MineCruiser *troop* (side seat passenger configuration) vehicles require adjustment of the Aeon spring position to reset suspension end of travel limits. This action will require the addition of a spacer to be installed. GEI recommend that this work be undertaken at the next opportunity during planned maintenance. Please contact GE Mining Industrea to make arrangements to complete this work.



Individual Recall: Mk7 MineCruiser Aeon Spring position

MineCruiser *Bus* (forward seating passenger configuration) vehicles require adjustment of the Aeon spring position to reset suspension end of travel limits. This action will require the addition of a spacer to be installed. GEI recommend that this work be undertaken at the next opportunity during planned maintenance. Please contact GE Mining Industrea to make arrangements to complete this work.

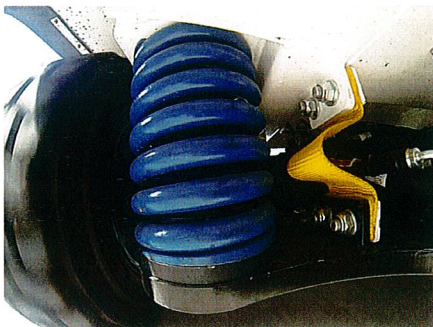

MineCruiser Suspension

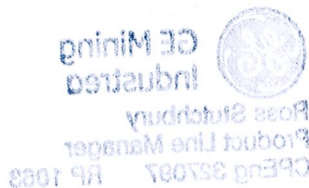



General Recall: Coolant Loss valve supply position - MineCruiser

The coolant pressure take off position on the MWM engine is out of range (height) for the correct application of the Coolant Loss Valve. This valve measures low pressure and the new coolant take off position ensures head pressure does not affect the setting or operation of the valve. A hose and fitting kit is available to connect the coolant loss signal from the oil manifold coolant gallery. Alternatively, the valve can be repositioned such that the coolant take of position is level with the valve location. Please contact GE Industrea as below to facilitate this work.



Coolant loss relocation

GE Industrea Thornton
02 40148500

GE Industrea Rutherford
02 40159000

GE Industrea Emerald
07 4982 0066

